

On Control Parameters Tuning for Active Queue Management Mechanisms using Multivariate Analysis

Tomoya Eguchi, Hiroyuki Ohsaki
Graduate School of Information
Science and Technology, Osaka University
Toyonaka, Osaka 560-8531, Japan
E-mail: {t-eguti, oosaki}@ist.osaka-u.ac.jp

Masayuki Murata
Cybermedia Center, Osaka University
Toyonaka, Osaka 560-0043, Japan
E-mail: murata@cmc.osaka-u.ac.jp

Abstract

In recent years, AQM (Active Queue Management) mechanisms, which support the end-to-end congestion control mechanism of TCP by performing congestion control at a router, have been actively studied by many researchers. AQM mechanisms usually have several control parameters, and their effectiveness depends on a setting of those control parameters. Therefore, issues on parameter tuning of several AQM mechanisms have been extensively studied using simulation experiments. However, in most of those studies, only a small number of simulation experiments are performed for investigating the effect of control parameters on the performance of AQM mechanisms. In this paper, we therefore statistically analyze a large number of simulation experiments using multivariate analysis, and quantitatively show how the performance of AQM mechanisms is affected by a setting of control parameters. In particular, we analyze the performance of three AQM mechanisms: GRED (Gentle RED), DRED (Dynamic-RED), and SRED (Stabilized RED), all of which are variants of RED (Random Early Detection). Through several numerical examples, we clarify how control parameters of GRED, DRED, and SRED have impact on their steady state performance measures such as the average queue length and the packet loss probability. We present a few guidelines for configuring control parameters of those AQM mechanisms.

1 Introduction

For solving problems of conventional Drop Tail routers, researches on AQM (Active Queue Management) mechanisms have been performed actively in the last few years [2]. AQM mechanisms control the queue length (i.e., the number of packets in router's buffer) by actively discarding ar-

riving packets before the router's buffer becomes full. For instance, one of typical AQM mechanisms called "RED (Random Early Detection)" [6] randomly drops an arriving packet with a probability being proportional to its average queue length. However, it is known that RED's effectiveness is heavily dependent on a setting of its control parameters. Moreover, another problem that the average queue length of RED in steady state depends on the number of active TCP connections has been reported [6, 4]. Hence, in the literature, several variants of RED — GRED (Gentle RED) [5], DRED (Dynamic-RED) [1], and SRED (Stabilized RED) [8] — have been proposed for solving problems of RED.

GRED is an improvement of RED by using an ad hoc approach [5]. In RED, when the average queue length becomes large, the packet drop probability is changed drastically. Hence, RED has a problem that the queue length becomes unstable when the average queue length is large. GRED solves this problem by gently changing the packet drop probability when the average queue length is large. Although extensive studies on RED have been performed by many researchers, the performance of GRED has not been fully investigated.

DRED is also an improvement of RED [1]. DRED solves the RED's known problem that the average queue length in steady state is dependent on the number of active TCP connections. DRED dynamically adjusts its packet drop probability in proportion to its average queue length. So, in DRED, the average queue length is not dependent on the number of TCP connections. However, similar to RED, the performance of DRED is significantly affected by a setting of its control parameters such as α , β , T , and L [1]. For example, simulation experiments show that α and L are directly related to its queue length and packet loss probability. However, effects of those control parameters on DRED's performance (e.g., the average queue length and the packet

loss probability) have not been quantitatively investigated.

Similar to DRED, SRED solves the RED's problem that the average queue length is dependent on the number of active TCP connections [8]. The key idea of SRED is to estimate the number of active TCP connections using a small cache called "zombie list". SRED determines its packet drop probability in proportion to the estimated number of active TCP connections. Hence, in SRED, the average queue length is almost independent of a setting of control parameters [8]. However, the performance of SRED has not been fully evaluated, and effects of SRED's control parameters on its performance have not been clarified.

In [3], we have proposed a method of statistically analyzing a great number of simulation results, which are obtained by changing control parameters diversely, using the multivariate analysis. We have quantitatively shown effects of RED's control parameters on its performance metrics. In this paper, we evaluate performance of GRED, DRED, and SRED using our analysis method proposed in [3]. Namely, we analyze effects of control parameters of three AQM mechanism on their performance metrics (i.e., the average queue length and the packet loss probability).

The organization of this paper is as follows. First, in Section 2, we briefly explain three AQM mechanisms, GRED, DRED, and SRED, which will be evaluated in this paper. In Section 3, we show the outline of the multiple regression analysis, which is one of representative multivariate analysis methods. We then briefly explain how the multiple regression analysis is applied for evaluating performance of AQM mechanisms. In Section 4, we explain our simulation model and parameters used in simulation experiments. In Section 5, we present analysis results of the multivariate analysis and discuss how control parameters of AQM mechanisms are related to their performance metrics. Finally, in Section 6, we summarize this paper and discuss future works.

2 Active Queue Management

2.1 GRED (Gentle RED)

GRED [5] is an improvement of RED (Random Early Detection) proposed in [6]. RED drastically changes the packet drop probability to one when the average queue length is large. Hence, when the average queue length is large, the queue length become unstable. GRED prevents the queue length from becoming unstable by gently changing the packet drop probability. In what follows, we briefly explain the algorithm of GRED. The packet dropping algorithm of GRED is essentially the same as that of RED. Please refer to [6] for the details of the RED algorithm.

GRED maintains the average queue length as well as RED. For every packet arrival, the average queue length \bar{q}

is updated as

$$\bar{q} \leftarrow (1 - w_q) \bar{q} + w_q q$$

where q is a current queue length, and w_q is one of RED's control parameters, which specify the weight of an exponential averaging. GRED determines the packet drop probability p_b based on the average queue length \bar{q} as

$$p_b = \begin{cases} 0 & \text{if } \bar{q} < \min_{th} \\ \max_p \left(\frac{\bar{q} - \min_{th}}{\max_{th} - \min_{th}} \right) & \text{if } \min_{th} \leq \bar{q} < \max_{th} \\ (1 - \max_p) \left(\frac{\bar{q} - \max_{th}}{\max_{th}} \right) + \max_p & \text{if } \max_{th} \leq \bar{q} < 2 \max_{th} \\ 1 & \text{if } \bar{q} > 2 \max_{th} \end{cases}$$

where \min_{th} is the minimum threshold, \max_{th} is the maximum threshold, \max_p is the maximum packet drop probability, and all are control parameters of GRED. GRED randomly drops an arriving packet with the probability p_a defined by

$$p_a = \frac{p_b}{1 - \text{count} \times p_b}$$

where count is the number of packets that have arrived at the router since the last packet dropping.

2.2 DRED (Dynamic RED)

RED has a problem that the average queue length is dependent on the number of active TCP connections. DRED solves this problem by using the feedback control, which adjusts the packet drop probability in proportion to its average queue length [1]. DRED is therefore able to stabilize the queue length at the target value without being dependent on the number of TCP connections.

We briefly explain the algorithm of DRED. DRED uses a fixed sampling interval, and the packet drop probability is updated every sampling interval. In what follows, we focus on a packet that arrives at the router in the n -th sampling interval. First, DRED obtains the error signal as

$$e(n) = q(n) - T$$

Next, the filtered error signal of $e(n)$ (denoted by $\hat{e}(n)$) is updated as

$$\hat{e}(n) = (1 - \beta) \hat{e}(n - 1) + \beta e(n) \quad (1)$$

where β is the DRED's control parameter, and specifies the weight of an exponential averaging. Finally, using $\hat{e}(n)$, DRED determines the packet drop probability $p_d(n)$ as

$$p_d(n) = \min \left[\max \left\{ p_d(n - 1) + \alpha \frac{\hat{e}(n)}{B}, 0 \right\}, \theta \right] \quad (2)$$

where B is the buffer size of the router, α is the DRED's control parameter specifying the feedback gain of the packet drop probability, and θ is the maximum of the packet drop probability. The packet drop probability p_d is updated every sampling interval, but DRED does not drop a packet if $q(n) < L$ for maintaining high resource utilization.

2.3 SRED (Stabilized RED)

In RED, the average queue length depends on the number of TCP connections. Moreover, RED does not distinguish misbehaving TCP flows, which will not reduce their transmission rates after packet losses. For solving these problems, SRED estimates the number of active TCP connections in a statistical manner, and determines the packet drop probability according to the estimated number of TCP connections [8]. For preventing unfairness caused by misbehaving TCP flows, SRED uses a different (i.e., large) packet drop probability for misbehaving TCP flows.

For estimating the number of active TCP connections, SRED uses "zombie list". The zombie list maintains information on each TCP connection, and its size is denoted by *list*. Namely, each entry of the zombie list consists of a flow identifier, a counter, and a time stamp. When a packet arrives at the router, SRED compares a randomly chosen entry from the zombie list with the entry corresponding to the arriving packet. If these entries coincide, the counter in the entry is increased by one. Otherwise, the entry is probabilistically replaced by the information on the arriving packet with probability p . With the zombie list, SRED estimates the number of active TCP connections. For distinguishing misbehaving TCP flows, the zombie list is also used. See [8] for the details of SRED.

We briefly explain the packet dropping algorithm of SRED. First, SRED compares a randomly chosen entry from the zombie list with the entry corresponding to the arriving packet. We focus on the n -th arriving packet. If these entries coincide, $H(n)$ is set to one. Otherwise, $H(n)$ is set to zero. The probability $P(n)$ that the zombie list contains the entry for the arriving packet is estimated by

$$P(n) = (1 - \alpha)P(n - 1) + \alpha H(n) \quad (3)$$

where α is the SRED's control parameter, and specifies the weight of an exponential averaging. Next, in proportion to the current queue length q , the packet drop probability $p_{sred}(q)$ is updated for every packet arrival as

$$p_{sred}(q) = \begin{cases} p_{max} & \text{if } \frac{1}{3}B \leq q < B \\ \frac{1}{4} \times p_{max} & \text{if } \frac{1}{6}B \leq q < \frac{1}{3}B \\ 0 & \text{if } 0 \leq q < \frac{1}{6}B \end{cases} \quad (4)$$

where B is the buffer size of a router. p_{max} is the SRED's control parameter, and limits the maximum of the packet

drop probability. Finally, SRED randomly drops an arriving packet with the probability p_{zap} defined by

$$p_{zap} = p_{sred}(q) \times \min \left(1, \frac{1}{(256 \times P(n))^2} \right) \times \left(1 + \frac{H(n)}{P(n)} \right) \quad (5)$$

3 Multiple Regression Analysis

Multivariate analysis is a set of techniques for statistically analyzing observed data for investigating correlation among multiple factors. Multivariate analysis is capable of systematically handling a huge amount of data. In this paper, we use a *multiple regression analysis*, which is one of several multivariate analysis techniques. Using the multiple regression analysis, we can analyze effects of multiple predictor variables (i.e., affecting factors) on a response variable (i.e., an influenced factor). In what follows, we briefly explain how the multiple regression analysis is applied to AQM mechanisms. Please refer to [7] for the details of the multiple regression analysis, and [3] for the details of the analysis method of AQM mechanisms using the multivariate analysis.

In this paper, we analyze effects of control parameters of AQM mechanisms on their performance metrics using the multiple regression analysis. We choose one of performance metrics of AQM mechanisms (i.e., the average queue length and the packet loss probability) as a response variable, and control parameters of AQM mechanism as predictor variables. We first obtain a number of simulation results by diversely changing control parameters of AQM mechanisms. From simulation results, we then have a pairwise scatter plot for different response variables. The pairwise scatter plot illustrates relations between each variable pairs as a scatter plot.

For instance, in the multiple regression analysis, linearity among response variables and predictor variables is assumed. By using a pairwise scatter plot, the correlation among response variables and response variables can be visually understood. Furthermore, using a pairwise scatter plot allows us to visually confirm whether outliers are contained in the measured response variables and predictor variables.

We next apply the multiple regression analysis to simulation results. For measuring the accuracy of the multiple regression analysis, R^2 (multiple R squared) will be used. When R^2 is close to zero, it implies that the multiple regression analysis is not successful, and that some factors other than predictor variables chosen affect the response variable. On the other hand, when R^2 is close to one, it implies that the multiple regression analysis is successful

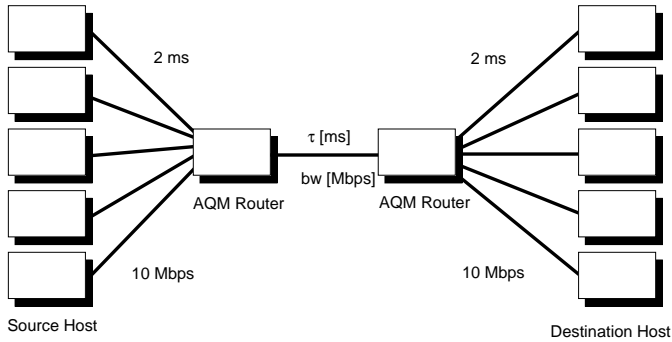

Figure 1. Simulation model.

Table 1. Parameter values used in simulation.

Bandwidth of the Bottleneck Link	1.5	[Mbit/s]
Propagation Delay of the Bottleneck Link	50	[ms]
Packet Size	1,000	[byte]
Buffer Size	100	[packet]

so that effects of control parameters of AQM mechanisms can be estimated from the regression coefficients.

4 Simulation

Figure 1 shows the simulation model used in this paper, which consists of five TCP connections and two AQM routers. Both AQM routers are either GRED, DRED, or SRED. In this network configuration, the link between two AQM routers is the bottleneck. In Tab. 1, we summarize network parameters used in our simulation.

In this paper, we obtain simulation results for either GRED, DRED, or SRED, by diversely changing its control parameters. Every simulation is run for 30 seconds. We use each simulation result of the last 5 seconds for calculating performance metrics of the AQM mechanisms such as the average queue length and the packet loss probability.

5 Analysis Result

In this section, we show analysis results of the multiple regression analysis to simulation results for three AQM mechanisms: GRED, DRED, and SRED.

5.1 GRED

Figure 2 shows the pairwise scatter plot displaying the relation among control parameters of GRED and its aver-

age queue length. Table 2 shows the result of the multiple regression analysis.

Figure 2 tells whether linear relation exists between each pair of control parameters and the average queue length of GRED. For instance, strong linear relation can be observed between min_{th} and the average queue length. Linear relation can also be observed between other control parameters (max_{th} or max_p) and the average queue length. This indicates that the assumption required for performing the multiple regression analysis (i.e., existence of linearity among response variables and predictor variables) is valid.

In Tab.2, “regression coefficient” is a coefficient of the regression equation corresponding to each predictor variable, and “standardized regression coefficient” is obtained by normalizing each regression coefficient. “ t -value” is the result of t -test, which investigates whether one of predictor variables affects the distribution of residuals of a regression equation, and “ P -value” is the probability that the distribution of residuals is the same when one of predictor variables is removed from the regression equation.

First, we focus on absolute values of the standardized regression coefficients. One can find that the standardized regression coefficient of min_{th} (the minimum threshold) is the largest. The values of max_p (the maximum packet drop probability), max_{th} (the maximum threshold), and w_q (the weight of exponential averaging) become small in this order. This means that effects of min_{th} , max_p , and max_{th} on the average queue length become small in this order. These results can be explained as follows. Since GRED does not drop a packet when the average queue length is less than min_{th} , the minimum value of the average queue length is determined by min_{th} . On the other hand, absolute values of standardized regression coefficients show that magnitude of effects of max_p and max_{th} on the average queue length is the half of that of min_{th} . In addition, the value of the standardized regression coefficient of w_q is very small (i.e., -0.02), and this shows that w_q hardly affects the average queue length.

In general, for avoiding buffer overflow and buffer underflow, it is desirable that the average queue length is stabilized at an appropriate value. To realize this, min_{th} should be configured so that the buffer underflow can be prevented. Then, max_p and max_{th} should be configured so that buffer overflow can be prevented. When we compare the analysis result in [3] with the analysis result for GRED, it can be found that in RED, max_{th} has the largest impact on the average queue length, whereas in GRED, min_{th} has. This is because GRED improves RED’s problem that the packet drop probability becomes one when the average queue length is larger than max_{th} . Namely, this implies that RED’s simulation results or analysis results cannot be used to configure control parameters of GRED.

Figure 3 shows the pairwise scatter plot displaying the

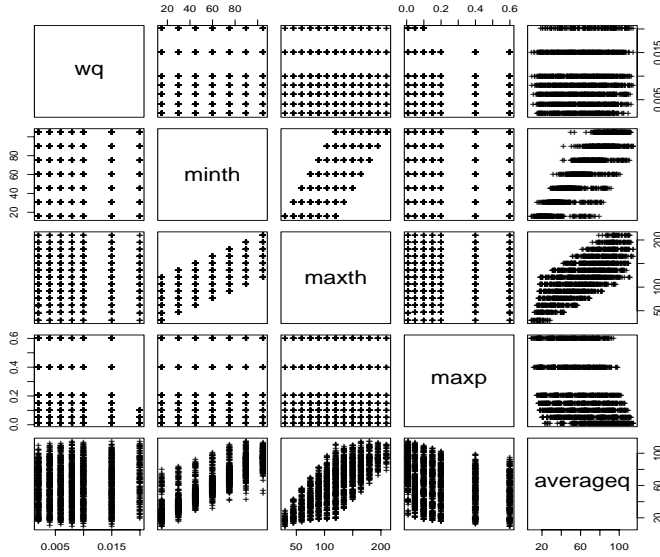

Figure 2. Pairwise scatter plot of GRED control parameters and average queue length

relation among control parameters of GRED and the packet loss probability. Table 3 shows the result of the multiple regression analysis investigating the packet loss probability of GRED. When we focus on absolute values of standardized regression coefficients, values of min_{th} , max_p , max_{th} and w_q become small in this order. This shows that the magnitude of effects of max_p and max_{th} on the packet loss probability is about 2/3 and 1/2 of that of min_{th} . The packet loss probability counts packet losses caused by GRED's intentional packet dropping and buffer overflow. By comparing Tab. 2 and Tab. 3, one can find that absolute values of standardized regression coefficients of min_{th} , max_p , max_{th} , and w_q are almost the same. This can be explained by the following reasons. Namely, (1) the packet loss probability in the network and the window size of TCP have very strong correlation [9], (2) since TCP has a window-based flow control, the average queue length of the bottleneck router is determined by the window size of TCP.

5.2 DRED

Figure 4 shows the pairwise scatter plot displaying the relation among α (the feedback gain for the packet drop probability), β (the weight of the exponential averaging), T (the target queue length), L (the minimum threshold), and the average queue length of DRED. Table 4 shows the result of the multiple regression analysis. By focusing on absolute values of standardized regression coefficients in Tab. 4, one

Table 2. Multiple regression analysis result for average queue length of GRED.

predictor variable	regression coefficient	standardized regression coefficient	t -value	P -value
intercept	15.23		24.41	0.00
w_q	101.32	0.02	3.01	0.00
min_{th}	0.57	0.67	70.82	0.00
max_{th}	0.17	0.28	29.49	0.00
max_p	-44.17	-0.34	-49.69	0.00
R^2	0.90			

Table 3. Multiple regression analysis result for packet loss probability of GRED.

predictor variable	regression coefficient	standardized regression coefficient	t -value	P -value
intercept	1.28		80.35	0.00
w_q	-1.96	-0.024	-2.29	0.02
min_{th}	-0.007	-0.53	-35.41	0.00
max_{th}	-0.003	-0.31	-20.90	0.00
max_p	0.77	0.36	33.86	0.00
R^2	0.75			

can find that the absolute value of T is the largest, then values of α , β , and L becomes small in this order. Note that the absolute value of the standardized regression coefficient of α , β , and L is less than 1/9 of that of T . As we have explained in Section 2.2, T is the target the queue length of DRED so that it should have direct impact on the average queue length. However, the correlation between T and the average queue length in Fig. 4 shows that the average queue length of DRED is not always equal to T ; i.e., the average queue length is scattered around T . On the other hand, standardized regression coefficients of α and β are small. This is because, as can be seen from Eqs.(1) and (2), α and β determine the DRED's transient characteristics, but do not affect steady state characteristics such as the average queue length.

Figure 5 shows the pairwise scatter plot displaying the relation among DRED's control parameters and the packet loss probability. Table 5 shows the result of the multiple regression analysis for the packet loss probability. By focusing on absolute values of standardized regression coefficients, one can find that the absolute value of T is the largest, and then values of α , L , and β become small in this

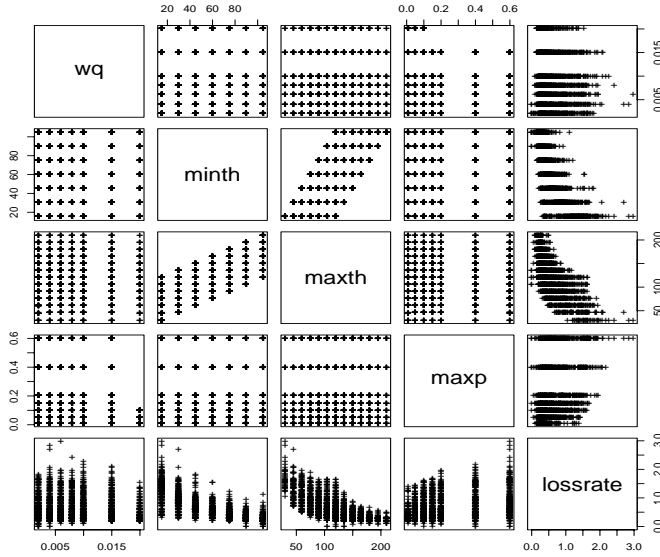

Figure 3. Pairwise scatter plot of GRED control parameters and packet loss probability

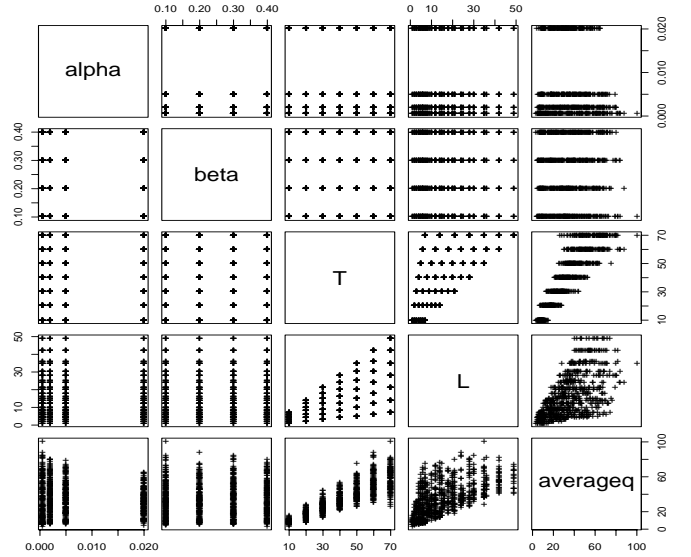

Figure 4. Pairwise scatter plot of DRED control parameters and average queue length

order. Similar to the case of the average queue length in DRED, standardized regression coefficients of α , β , and L are very small (i.e., less than 1/9 of the standardized regression coefficient of T).

From these observations, we conclude that the control parameter T has the largest impact on DRED's performance metrics (i.e., the average queue length and the packet loss probability) whereas other control parameters have little impact. Hence, when configuring DRED's control parameters, only the control parameter T should be chosen carefully so that neither buffer overflow nor buffer underflow occurs.

5.3 SRED

Figure 6 shows the pairwise scatter plot displaying the relation among SRED's control parameters and the average queue length. Table 6 shows the result of the multiple regression analysis for the packet loss probability.

We focus on the value of R^2 (multiple R squared), the value of the multiple R squared of SRED is small (i.e., 0.54). This means that the average queue length of SRED cannot be expressed by the sum of predictor variables (i.e., control parameters of SRED). This implies that the algorithm of determining the packet loss probability $p_{sred}(q)$ of SRED is non-linear to the average queue length (Eq.(4)).

By focusing on absolute values of standardized regression coefficients, it can be found that the standardized re-

gression coefficient of α (the feedback gain of the packet drop probability) is the largest, and then values of p_{max} (the maximum packet drop probability), $list$ (the size of the zombie list), and p (the probability for updating the zombie list) are very small. This means that the control parameter α affects the average queue length, but other control parameters (p_{max} , $list$, and p) hardly affect the average queue length. The pairwise scatter plot in Fig. 6 shows that variation of the average queue length becomes large as α becomes large. This is because when α is large, the estimation of the number of TCP connections becomes inaccurate, leading the queue length to be unstable.

Finally, Fig. 7 shows the pairwise scatter plot displaying the relation among SRED's control parameters and the packet loss probability. Table 7 shows the result of the multiple regression analysis for the packet loss probability.

As with the result of the multiple regression analysis for SRED (Tab.(6)), the value of the multiple R squared is small (i.e., 0.47).

By focusing on absolute values of standardized regression coefficients, one can find that almost the same tendency as the result of the multiple regression analysis for the average queue length is observed. Namely, the absolute value of the standardized regression coefficient of α is about as twice as that of p_{max} , and standardized regression coefficients of $list$ and p are very small.

From these observations, when configuring control parameters of SRED, we should set α and p_{max} to be small

Table 4. Multiple regression analysis result for average queue length of DRED.

predictor variable	regression coefficient	standardized regression coefficient	t -value	P -value
intercept	1.08		1.04	0.30
α	-233.42	-0.09	-5.70	0.00
β	3.51	0.02	1.24	0.22
T	0.83	0.86	38.92	0.00
L	0.05	0.03	1.49	0.14
R^2	0.79			

Table 5. Multiple regression analysis result for packet loss probability of DRED.

predictor variable	regression coefficient	standardized regression coefficient	t -value	P -value
intercept	4.51		56.79	0.00
α	1.85	0.02	1.15	0.25
β	0.10	0.02	0.93	0.35
$\log T$	-0.92	-0.82	-33.00	0.00
$\log L$	-0.05	-0.06	-2.52	0.01
R^2	0.75			

values for preventing the average queue length and the packet loss probability of SRED to become large. On the contrary, $list$ and p can be configured freely without paying attention to SRED's steady state characteristics.

6 Conclusion

In this paper, we have evaluated the performance of GRED, DRED, and SRED using the analysis method proposed in [3]. We have analyzed quantitatively the effects of control parameters of three AQM mechanisms on their performance metrics (i.e., the average queue length and the packet loss probability). We have found (1) in GRED, effects of min_{th} , max_p , and max_{th} on the average queue length and the packet loss probability become small in this order whereas w_q has little impact, (2) in DRED, T has direct impact on the average queue length and the packet loss probability, and other control parameters α , β , and L have little impact, and (3) in SRED, the average queue length and the packet loss probability are largely affected by control parameters α and p_{max} in this order, and other control parameters, p and $list$, have little impact. In addition,

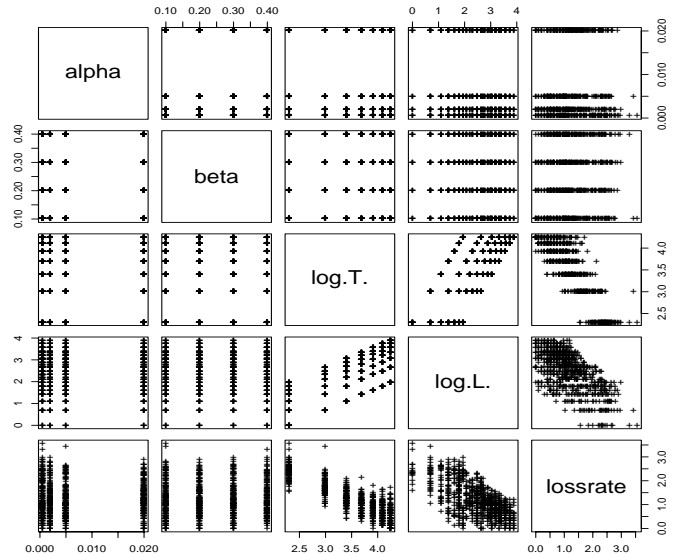

Figure 5. Pairwise scatter plot of DRED control parameters and packet loss probability

we have discussed how control parameters of AQM mechanisms should be configured based on our analysis results.

In this paper, we have analyzed effects of control parameters of three AQM mechanisms on their steady state performance. Our analytic approach can be applied to investigate how system parameters such as the bottleneck bandwidth and the propagation delay affect performance of AQM mechanisms. Hence, we are currently working on investigating effects of system parameters on GRED, DRED, and SRED using the multivariate analysis.

References

- [1] J. Awewa, M. Ouellette, and D. Y. Montuno. A control theoretic approach to active queue management. *Computer Networks*, 36:203–235, 2001.
- [2] B. Braden et al. Recommendations on queue management and congestion avoidance in the Internet. *Request for Comments (RFC) 2309*, Apr. 1998.
- [3] T. Eguchi, H. Ohsaki, and M. Murata. Multivariate analysis for performance evaluation of active queue management mechanisms in the Internet. In *Proceedings of SPIE's International Symposium on the Convergence of Information Technologies and Communications (ITCom 2002)*, July 2002.
- [4] W.-C. Feng, D. D. Kandlur, D. Saha, and K. S. Shin. Techniques for eliminating packet loss in congested TCP/IP networks. Technical Report CSE-TR-349-97, U. Michigan, Apr. 1997.

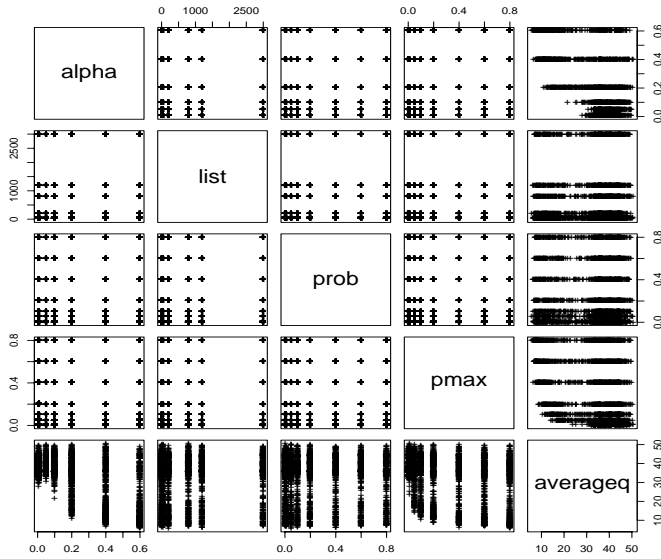

Figure 6. Pairwise scatter plot of SRED control parameters and average queue length

- [5] S. Floyd. Recommendations on using the gentle variant of RED, May 2000. available at <http://www.aciri.org/floyd/red/gentle.html>.
- [6] S. Floyd and V. Jacobson. Random early detection gateways for congestion avoidance. *IEEE/ACM Transactions on Networking*, 1(4):397–413, Aug. 1993.
- [7] L. C. Hamilton. *Regression with Graphics*. Duxbury Press, Belmont, California, 1992.
- [8] T. J. Ott, T. V. Lakshman, and L. Wong. SRED: Stabilized RED. In *Proceedings of IEEE INFOCOM '99*, pages 1346–1355, Mar. 1999.
- [9] J. Padhye, V. Firoiu, D. Towsley, and J. Kurose. Modeling TCP throughput: a simple model and its empirical validation. In *Proceedings of ACM SIGCOMM '98*, Sept. 1998.

Table 6. Multiple linear regression analysis result for average queue length of SRED.

predictor variable	regression coefficient	standardized regression coefficient	t -value	P -value
intercept	51.55		119.85	0.00
α	-41.19	-0.69	-60.01	0.00
$list$	0.00	0.006	0.55	0.58
p	0.21	0.003	0.30	0.76
p_{max}	-12.68	-0.21	-18.50	0.00
R^2	0.54			

Table 7. Multiple regression analysis result for packet loss pability of SRED.

predictor variable	regression coefficient	standardized regression coefficient	t -value	P -value
intercept	0.25		17.85	0.00
α	1.11	0.62	50.55	0.00
$list$	0.00	0.004	0.30	0.76
p	0.01	0.007	0.55	0.58
p_{max}	0.53	0.30	24.37	0.00
R^2	0.47			

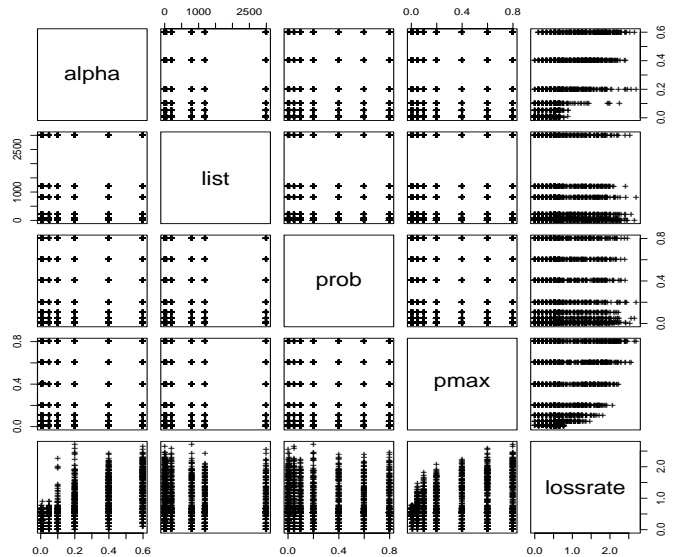

Figure 7. Pairwise scatter plot of SRED control parameters and packet loss pability